

NMEA 2000® A Digital Interface for the 21st Century

Lee A. Luft, *U.S. Coast Guard Research and Development Center*
Larry Anderson, *National Marine Electronics Association*
Frank Cassidy, *National Marine Electronics Association*

ABSTRACT

Ships and boats are outfitted with suites of electronics including everything from desktop and laptop computers, and GPS to depth sounders and nautical chart data on diskettes. This paper describes the new standardized data protocol and interface that permits inexpensive communications among these devices. The National Marine Electronics Association (NMEA) has introduced a new standard (NMEA 2000®) for data communications among shipboard electronic devices. A single network cable replaces a myriad of cables used by today's methods of interconnection. The NMEA 2000® network can accommodate navigation equipment, power generation, engines and machinery, piloting and steering systems, fire alarm, and controls. Data, commands, and status all share the same cable at speeds 26 times greater than the NMEA 0183 serial interface. NMEA 2000® is self-configuring, no setup is required, and no master controller is needed. Equipment may be added or removed without shutting down the network. This paper provides an in-depth description of NMEA 2000®, including its capabilities, application within and beyond the marine industry, and national and international acceptance.

INTRODUCTION

NMEA 2000® is a low-cost serial data network operating at 250 kbits/second utilizing the Controller Area Network (CAN) integrated circuit (IC). CAN was originally developed for the automotive industry, and now is used in numerous industrial applications and produced by dozens of IC manufacturers. NMEA 0183 is a serial data interface operating at 4.8 kbits/second utilizing standard asynchronous communications of the type found on the serial port of a PC. The key difference, apart from the

obvious one of operating speed, is that NMEA 0183 is an interface and NMEA 2000® is a network.

The NMEA 2000® network allows multiple electronic devices to be connected together on a common channel for the purpose of easily sharing information. Because it is a network, and because multiple devices can transmit data, a more comprehensive set of rules is required that dictate the behavior of the members of the network. CAN automatically provides some of these rules – mostly for control of access to the network, packet transmission, and for error detection. Similar to NMEA 0183, NMEA 2000® defines standard data formats and definitions, but in addition provides more extensive network management rules for identifying nodes on the network, sending commands to devices, and for requesting data.

Besides the greater amount of control and integration provided, NMEA 2000® replaces with a single cable all of the wiring of up to 50 NMEA 0183 interconnections and can handle the data content of between 50 and 100 NMEA 0183 data streams.

BACKGROUND

Integration of shipboard systems, sensing and control within systems, sharing of information, and collecting of data is occurring at an increasing rate on board vessels. These operations are happening in many parts of the vessel from the engine room, to the bridge, to administrative personnel, and even off of the ship to the owner's office by way of satellite communications links. To varying degrees, these applications exist on ships, coastal vessels, fishing vessels, and recreational boats and each of them require standardized data communications with varying capabilities. A general shipboard configuration is shown in the figure Shipboard Networks and Interfaces.

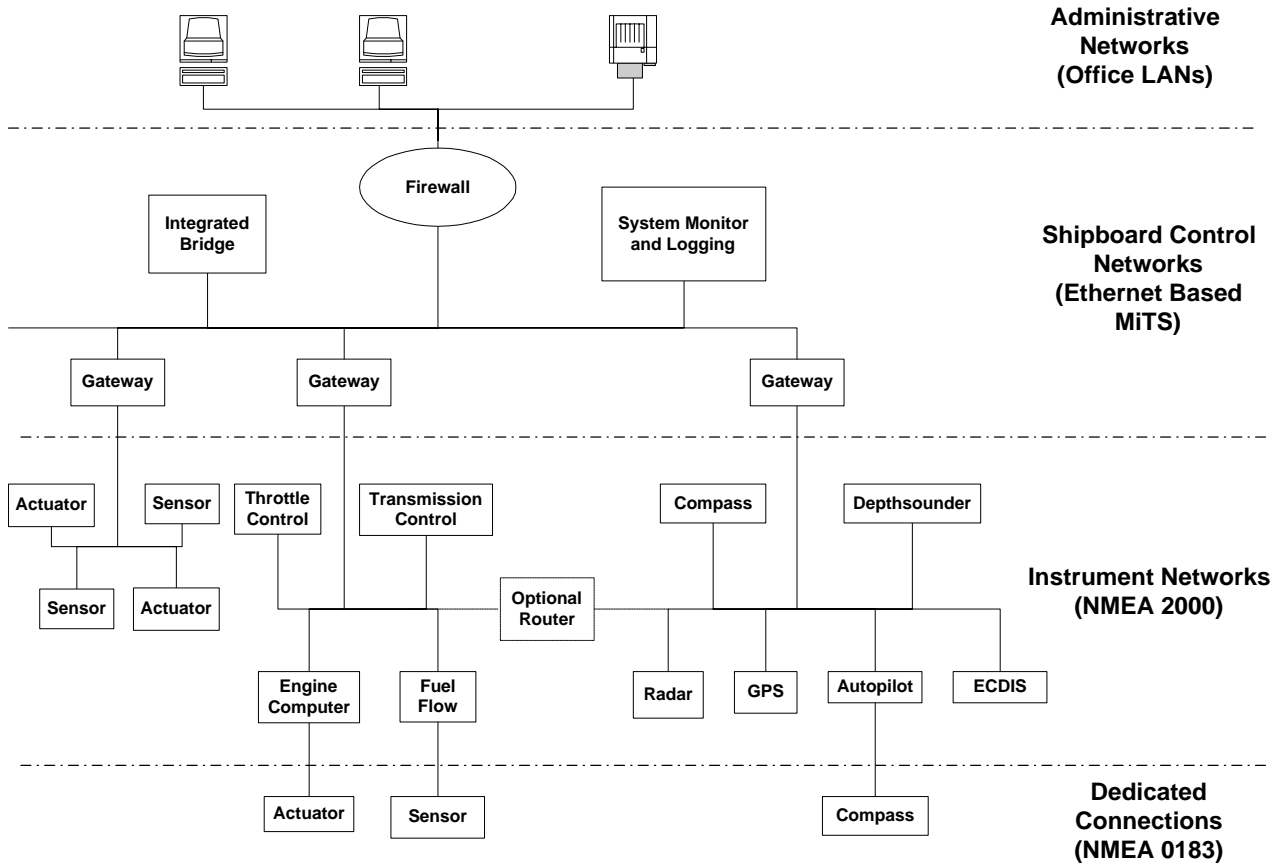

Shipboard Networks and Interfaces

The applications for data transfer cover the broad spectrum of simple data buses that distribute data, such as NMEA 0183, all the way to full-scale office-type local-area-networks (LANs). Each of these applications has different, and sometimes conflicting, requirements.

From a big-picture point of view a shipboard application may have one or more LANs with PCs connected to printers, scanners, backup systems, etc. While these systems are important in running the ship, and may be used for payroll, inventory, and e-mail, they are not safety-critical systems nor do they have real-time requirements. They are built using commercial off-the-shelf Ethernet-based components and use software provided by Microsoft and others. Decisions that affect the operation of the ship and involve the safety of the ship, the crew, the passengers, the cargo, and the environment are generally made on the bridge or other control centers as part of Integrated Bridge Systems and Integrated Ship Control Systems. To efficiently make decisions and to carry them out requires access to many of the shipboard systems. These systems might include navigation, power generation, engines and machinery, fire alarm and control, etc. The unique maritime nature, security, availability, redundancy, and latency

requirements of these connections preclude the use of ready made office-type LANs. Yet the data and speed requirements are similar. The International Electrotechnical Commission (IEC) standard IEC 61162-4 is addressing these network requirements. Based on a Norwegian initiative called MiTS (Maritime Information Technology Standard), this Ethernet-based system, designed for operation up to 100 megabits/second, has undergone shipboard implementation and testing and is likely to see increasing use onboard ship.

At the basic level, and in wide use today, NMEA 0183 (IEC 61162-1) provides serial-data distribution from a single transmitter to multiple receivers. Operating at 4800 bits/second this protocol has the capability of delivering approximately ten messages, or sentences, per second. This has generally proven adequate when a single device is broadcasting data for use by other equipment. But it quickly reaches a limit when systems start to combine data. However, its use is expected to continue well into the future for simpler applications, redundant or backup data connections, and when direct device-to-device connections are needed.

Increasingly, modern marine electronic equipment requires data from multiple sources to enable the host of features and function that can be available to the mariner. Without a network standard to provide this data integration, equipment designers must provide multiple data inputs, which involve expense and additional wiring, or use devices that "merge" data onto a single channel. Individual systems on a vessel, such as engine machinery or navigation systems, perform relatively dedicated functions, often have real-time requirements measured in milliseconds, and need fewer connected nodes. These systems tend to be smaller and more self-contained when compared to other vessel networks, and carry less data volume. Because this network application integrates inexpensive sensors and actuators into larger systems, the cost per node must be far less than in other shipboard applications. This network application is addressed by NMEA 2000® (IEC 61162-3).

Now that we know how it fits into the overall shipboard application, the remainder of this article describes NMEA 2000® (IEC 61162-3) a low cost, moderate capacity (250 K-bits/second), bi-directional multi-transmitter/multi-receiver instrument network to interconnect marine electronic devices.

OVERVIEW

The NMEA 2000® standard contains the requirements for the minimum implementation of a serial-data communications network to interconnect marine electronic equipment onboard vessels. Equipment designed to this standard will have the ability to share data, including commands and status, with other compatible equipment over a single signaling channel.

Data messages are transmitted as a series of data frames, each with robust error checking and confirmed frame delivery. Data frames contain, in addition to control and error-checking bits, an 8-byte data field and a 29-bit identification field that sets message priority and identifies the data message, the source, and the destination. As the actual data content of a data frame is at best 50% of the transmitted bits, this standard is primarily intended to support relatively brief data messages, which may be periodic, transmitted as needed, or on-demand by use of query commands. Typical data includes discrete parameters such as position latitude and longitude, GPS status values, steering commands to autopilots, finite parameter lists such as waypoints, and moderately sized blocks of data such as electronic chart database updates. This standard is not necessarily intended to support high-bandwidth applications such as radar, electronic chart or other video data, or other intensive database or file transfer applications.

The standard defines all of the pertinent layers of the International Standards Organization Open Systems Interconnect (ISO/OSI) model, from the Application Layer to the Physical Layer, necessary to implement the required NMEA 2000® network functions.

The components of an NMEA 2000® network are:

- Physical Layer. Fully defined by the standard, including signaling voltages, cables, and connectors.
- Data Link Layer. Defined by ISO 11783-3 with additional requirements specified by the standard.
- Network Layer. To be defined in future versions of the standard.
- Network Management. Defined by ISO 11783-5 with additional requirements specified by the standard.
- Application Layer. Fully defined by the standard and includes a provision for manufacturer's proprietary messages.

Important characteristics of the NMEA 2000® network are summarized in the Network Characteristics table. Of interest is the maximum wire-length of the network, now set at 200 meters. The maximum length of the network is controlled by the CAN requirement that all nodes on the network sample the same bit at the same time. Theoretically this translates to the following:

- 1,000 kbits/second - 25 meters
- 500 kbits/second - 75 meters
- 250 kbits/second - 200 meters
- 125 kbits/second - 500 meters
- 62.5 kbits/second - 1100 meters

Problems can be envisioned however, if nodes operating at different bit rates are connected to a network segment. The standard is currently fixed at the 250kbits/second data rate and corresponding 200-meter network length.

This standard defines data formats, network protocol, and the minimum physical layer necessary for devices to interface. In a sense it may be considered a pipeline for carrying information. How the pipeline is used for specific applications must sometimes be specified by performance standards for equipment expected to use the network. A performance standard for an electronic chart display system, for example, expecting an automatic position input must specify that the reference datum be provided along with the position fix message. In addition, single point-of-failure conditions could exist that are capable of disrupting network operation. For critical applications it may be necessary to employ fail-safe designs (e.g., dual networks, redundant cables and network interface circuits) to reduce the possibility of network failure. These methods are beyond the scope of the NMEA 2000® standard but must be considered when networks are installed in certain applications.

Network Characteristics	
Network architecture	<ul style="list-style-type: none"> • Bus (parallel) wiring configuration using 4-conductor twisted-pair wire to carry power to operate the interface and data signals. • Linear network with end terminations and multiple short-length drop cables connecting the backbone cable to individual nodes
Network operation	<ul style="list-style-type: none"> • Network access: Carrier Sense/Multiple Access/Collision Arbitration using CAN (Controller Area Network) • Multi-master network operation (no central control node) • Self-configuring • Special network tools, desirable for diagnostic purposes, are not necessary for operation
Network size	<ul style="list-style-type: none"> • Physical nodes: Up to 50 connections • Functional nodes: Up to 252 network addresses • Length: Up to 200 meters (at 250kbits/second bit rate)

THE PHYSICAL LAYER

This layer defines the electrical and mechanical aspects of the physical link between network connections, and references characteristics of the CAN devices and network interfaces to be used in NMEA 2000®.

The electrical characteristics of the physical layer are dictated by the following:

- Media access uses CAN as defined by ISO 11898.
- CAN utilizes dominant/recessive bit transmission.
- Time delays and network loading limit bit rate and network length.
- Differential signaling improves noise immunity.
- Network single-point common signal reference controls ground voltage levels and reduces RFI.

Differential signaling indicates that powered interface circuits and a signal-reference common to all nodes on the network is required. A single-point common reference is specified in order to avoid radio-interference caused by ground loops and to maintain control of ground-voltage levels between nodes such that they remain within the common-mode range (approximately +/-2.5 Volts) of the network transceiver circuits. The standard allows the use of the vessel's 12-Volt battery to power the network, if the length of the backbone cable and the number of nodes are small enough. Alternatively, one or more regulated power supplies may be used to power the network.

Single-point power and common may be distributed via the network backbone cable as previously required, or for heavier current, by dedicated twisted-pair wires to individual devices. This feature allows equipment to

draw additional operating current from the network power source and to be built with minimum interface complexity. In all cases the power and common for the interface circuits must not connect to other power or ground in a network device. This isolation may be achieved in a number of ways. One is by use of isolation circuits (e.g., optoisolators) within the device, either at the interface or at specific places where the equipment connects to other devices. Another way is by assuring that no power or ground connections, other than the network power and network common, connect to the device. The latter method is suitable for equipment such as displays or sensors that have no interfaces other than with the NMEA 2000® network, can draw all of their operating current from the network source, and have isolated packaging and mounting designs.

The figure below illustrates a typical physical layer interface circuit using available transceiver integrated circuits meeting the requirements of ISO 11898. Ground isolation, illustrated with optoisolators, is shown between the network and the CAN controller and other device circuits (e.g., microprocessor and other circuits). However, as pointed out above, isolation from other circuits may be accomplished by other means.

The illustrated transceiver circuit requires regulated +5 Volt power that is provided by the Regulator and Protection circuits. The purpose of the protective circuits is to prevent damage to the regulator and the interface circuits from overvoltage and reverse voltage. No permanent damage should result from a voltage level of +/-18.0 Volts or less applied between any two wires in the interface for an indefinite period of time or from miswiring the interface lines in any combination.

THE MAIN POINTS OF THE PHYSICAL LAYER

ENVIRONMENTAL AND RADIO FREQUENCY INTERFERENCE

NMEA 2000® implementations must meet the Durability and Resistance to Environmental Conditions described in Section 8 of IEC 60945 and meet the Unwanted Electromagnetic Emissions and the Immunity to Electromagnetic Environment conditions of Sections 9 and

the state of the network is Dominant. The interface must be designed so that the signal lines are in the Recessive state when node power is off.

The AC and DC voltage parameters of the network signals are specified by ISO 11898. The nominal voltage levels are:

- Dominant state:
 $CAN+ = 3.5V$ $CAN- = 1.5V$ $V_{diff} = CAN+ - CAN- = 2.0V$

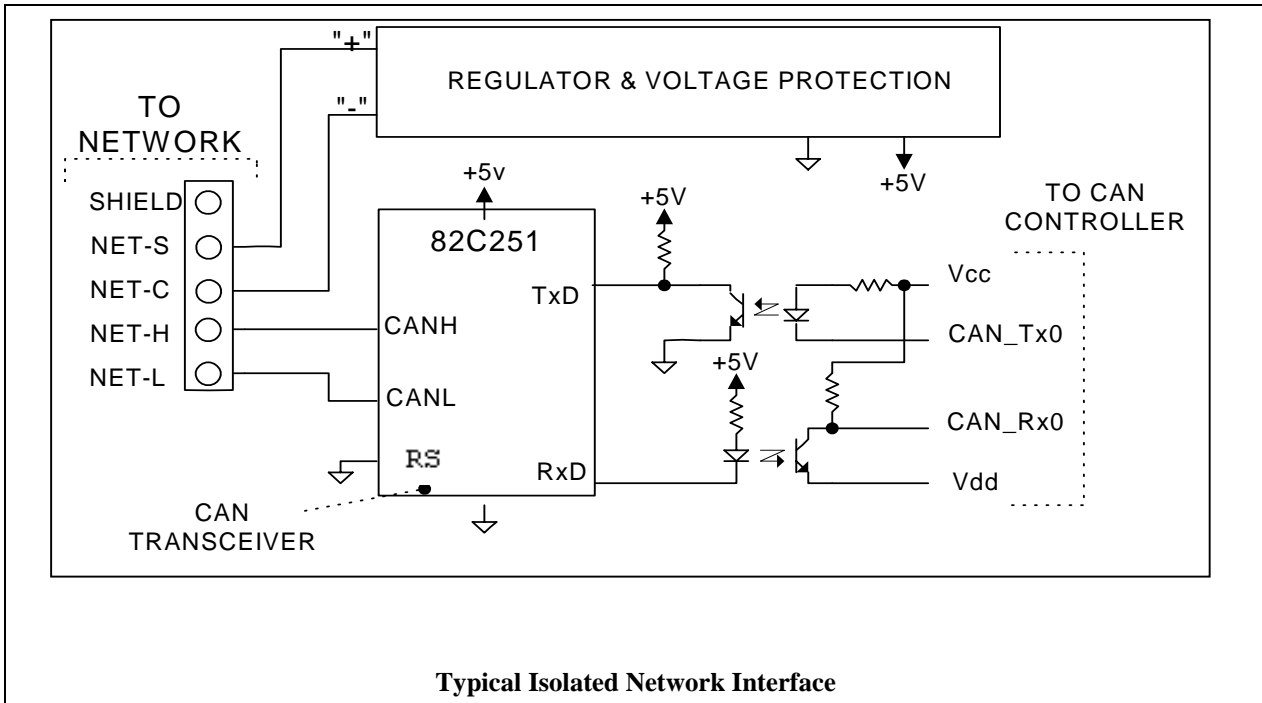

10 of IEC 60945. Shielded cables are recommended, and may be necessary to meet these latter requirements.

GROUND ISOLATION

AC and DC isolation is required between all of the terminals at the interface connector, with the network cables disconnected, and any other ship's ground or voltage sources. As discussed above this can be accomplished with isolation devices such as opto-isolators or by wiring and packaging design. For most applications, except those with very low power needs, the isolated interface is the preferred implementation.

NETWORK SIGNALING

The two signal lines carry differential signals measured with respect to the network power common. The signals on the network represent two states: Dominant state or Logic '0', and Recessive state or Logic '1', during the transmission of the Dominant state by one or more nodes

- Recessive state:
 $CAN+ = 2.5V$ $CAN- = 2.5V$ $V_{diff} = CAN+ - CAN- = 0.0V$
- Common Mode range:
 Difference in network common voltage between nodes: -2.5 to +2.5 Volts

NETWORK POWER

The interface circuits must operate over the range of 9.0 to 16.0 Volts DC. The voltage for the interface can either be supplied from the network backbone cable or supplied by a dedicated twisted-pair power cable connected only between a single node and the network power source (the vessel's battery or one regulated power supply). The amount of current delivered by the network cable is limited. When a dedicated power connection is used the node is allowed to draw additional current but the connections must be labeled, and physically separated and

isolated from other power and ground connections. Under no condition may the node power or ground be connected to other power or ground in the equipment.

To aid in planning network installations manufacturers are required to specify the power rating for each connected device as a "load equivalency number". The actual power source for the network can be either a single-point connection to the vessel's battery or one or more isolated power supplies distributed along the network. The size and routing of the cables must be carefully considered. As the number of nodes with high load equivalency numbers increase, DC voltage loss in the cables quickly becomes the limiting factor for network length rather than the propagation time for the signals. For networks of shorter length and with a lower number of connected devices the ship's battery may be used to power the network nodes directly. In place of the battery, electrically isolated regulated power supplies may be used if it is necessary to extend the size of the network.

CABLES AND CONNECTORS

Two methods are provided for connecting to the network backbone cable: a standard connector or barrier strips. These connections are used for connecting segments of backbone cable together, for connecting terminations at the two ends of the cable, for connecting the network power source, and for connecting nodes. The drop cable, the short cable running from the backbone connection to the node equipment, may connect to the equipment anyway the manufacturer chooses. It is the connections at the backbone that are controlled by the NMEA 2000® standard.

Barrier strips are only recommended when the connections are made in a protected location, or when they are installed in a weatherproof enclosure, thus meeting the requirements for Resistance to Environmental Conditions for exposed equipment in IEC 60945. Barrier strips positions must be either numbered or color-coded in accordance with the definitions in the standard.

The connector selected for the NMEA 2000® backbone is a 5-pin type used in industrial networks and is available from multiple sources (including Molex, Turck Inc., Methode Components, and Daniel Woodhead Company). Two sizes of the connector may be used depending upon the choice of heavy or light backbone cable. The connectors are available as 3-port "T" connectors, cable-end connectors, bulkhead-mount connectors and special configurations with internal termination resistors.

Cable specified for the network must meet both the characteristic impedance and propagation delay requirements for use as a transmission line, and also the wire-size needs of the DC power distribution function of

the cable. The cable lengths on the network, the number of nodes connected, the distribution of the nodes, and the location of the power source connection(s) into the backbone cable determine the actual cable requirements in a particular installation. Two cable sizes are specified and can be used as needed in an installation. NMEA 2000® Heavy cable is 5-wire consisting of two shielded-twisted-pairs and a common shield drain wire. The wire pairs are No. 16 AWG (1.33 sq. mm) for DC power and No. 18 AWG (0.83 sq. mm) for signals. NMEA 2000® Light cable uses No. 22 (0.38 sq. mm) and No. 24 (0.24 sq. mm) respectively.

The cable specified has a defined color code, in the event that these colors are not available the substitute cable must be marked according to the standard.

THE DATA LINK LAYER

The need for instrument-type networks is not unique to marine applications. The same ability to share information, collect sensor data, and control processes exists in the industrial environment, on land vehicles, and on the manufacturing floor. CAN was originally developed for use in vehicles and has since found its way into many other arenas. Although the applications may differ, many of these networks share the same need for control and management of the data communications on the network. The Society of Automotive Engineers (SAE) has developed a CAN-based network for use in trucks, buses and trailers. This SAE J1939 standard was later adopted by the International Organization for Standardization (ISO) for use with agricultural machinery and implements. While these applications have differing types of data and commands to transfer, and differing requirements for the physical layer, the job of setting up and managing the data communication on the network is very similar to that needed for NMEA 2000®.

For these reasons, and to ease the acceptance of NMEA 2000® as an international standard for maritime applications, NMEA 2000® references the data link layer of the international standard ISO 11783-3 which is virtually identical to the SAE data link layer SAE J1939-21. This international standard is to be used in its entirety, but in addition the NMEA 2000® data link layer provides enhanced features and functionality. These additions better support the type and format of data contained in NMEA 2000®, and support the unique way that electronic devices are designed, installed, and operate on board vessels.

CONTROLLER AREA NETWORK (CAN)

Like the physical layer, some of the requirements of the data link layer are dictated by the choice of CAN for media access. CAN is a microprocessor peripheral developed jointly by Intel and Bosch. This device, which

can be compared to the UART that is used at the serial port of all PCs and laptops, and is the input/output mechanism that handles NMEA 0183 data for virtually all marine electronic equipment, is attached to or is part of a microprocessor. Nearly every integrated circuit company manufactures CAN ICs today. Much more capable than a UART, the functions of CAN are to:

- Generate the serial bit-stream that is to be transmitted on the network.
- Gain access to the network when the equipment has data to send. It does this by sensing when the network is not busy. If there is a collision with another device trying to put data on the network CAN automatically compares each transmitted bit and arbitrates access on a bit-by-bit basis with Dominant bits winning. With this "Carrier Sense Multiple Access - Non Destructive - Bit Wise Arbitration" (CSMA-ND-BWA) method, there is no wasted network time due to collisions.
- Perform error checking and automatic retransmission of bad messages. CAN also automatically determines when its node is having repeated errors and will automatically take a node off-line to protect the rest of the network.

The serial data frame used by CAN has a 29-bit identification field and from zero to eight data bytes. In addition the frame contains start of frame and end of frame bits, reserved bits, frame control bits, a 15-bit CRC error detection field, and acknowledgement bits.

DATA LINK LAYER TASKS

The tasks of the data link layer are to:

- Define the way that the CAN 8-byte data field and the 29-bit identification field are used.
- Provide a method for sending manufacturer's

proprietary messages.

- Define ways of transmitting data that cannot fit in a single 8-byte CAN frame.
- Define a set of common messages for requesting data, sending commands to equipment, and acknowledging requests and commands.

CAN FIELD USAGE

NMEA 2000® adopts the SAE J1939 / ISO 11783 use of the identification field as shown below in the CAN Identification Field table. The highest-order bits, the first ones transmitted, are network access priority bits. Each of the bits in the identification field are used during the arbitration process when there is a network access conflict, but these bits come into play first. After a reserved-bit field the data being transmitted in the data field is identified next. Messages are either broadcast for use by all other nodes (such as a GPS position), or may be addressed to a specific node (a reset command for example). Broadcast messages are identified by a 2-byte value (bits 8 to 23). Addressed messages are identified by 1-byte (bits 16 to 23) and the second byte is used as the address of the recipient. The final byte of the identification field always contains the address of the transmitting node.

Most messages are designed as broadcast messages. Since only 1-byte is available for addressed messages this type is usually used for network management (requests, generic commands, acknowledgement, error reports, and manufacturer proprietary addressed messages).

The functional source address is contained in every transmitted frame and the destination address is contained in every frame that is not a global message. The

CAN Identification Field		
26 - 28	Priority	These bits have the most impact during network access arbitration
24 - 25	Reserved	Reserved for future use
16 - 23	Data ID Byte A	High-order byte of the parameter group number of the data being transmitted
08 - 15	Data ID Byte B	<ul style="list-style-type: none"> • Low-order byte of the parameter group number for global addresses, or • the destination address for non-global data groups
00 - 07	Source Address	Address of the transmitter

“address” concept is important since the number of physical connections to the network is limited. Physical network connections are not directly identified by a name or specific address and a single physical connection may be the location of more than one functional address. The maximum number of functional connections to the network is 252 and exceeds the number of physical connections.

MESSAGE SIZE

Messages that have eight bytes or less of data are sent as a single CAN frame. When more than 8-bytes are to be sent, one of two methods may be used. Multi-packet data up to 1,785 bytes may be sent according to an ISO 11783-3 protocol that places this data in a transport “envelope” and sends it to either a global or specific address. Flow control is provided so that when sending data to a specific address the recipient can start, stop, and control the flow of data. Unfortunately, when data is sent this way its identity is lost until the “envelope” is opened up to find out what data is being received. Because many of the messages defined for use with NMEA 2000® exceed 8-bytes (but do not require the 1,785 bytes capacity of Multi-packet), NMEA 2000® allows use of Fast-packet transmission for sending up to 223 bytes of data with their own identity. This method allows sequential frames to be sent. The first frame uses two data bytes to specify the size of the message, a sequence counter to distinguish separate Fast-packet messages of the same type, and a frame counter. Each additional frame uses a single data byte for the sequence counter and frame counter.

REQUESTS AND COMMANDS

The final capability of the data link layer is a to provide standard messages for requesting data or commanding another device, and an acknowledgement message to be used when the request or command cannot be complied with.

NMEA 2000® expands the capabilities of ISO 11783-3 by providing the command message that may be used to set values or cause actions to be taken at the receiving device. Additionally the request message provided by NMEA 2000® allows the transmission interval of requested data to be set, and allows messages to be requested by specified fields contained in the message. For example, a message containing Waypoint Information may contain waypoint position, waypoint name, waypoint number, and waypoint symbol. The NMEA 2000® request message allows for the request of Waypoint Information by specifying the waypoint name (or number), a field within the Waypoint Information message.

NETWORK MANAGEMENT

Similar to the data link layer, the procedures used in the management of the NMEA 2000® network are aligned with international standard ISO 11783-5 that is based on SAE J1939-81. Network management is responsible for:

- The claiming and assignment of addresses on the network.
- The identification of the devices connected to the network.
- Network initialization at power-on.

It is a requirement that each device connected to the network have an address. There are 256 possible addresses (1-byte). A total of 252 addresses (0 – 251) are available for use, No. 255 is designated as a global address, used for sending addressed messages to all nodes, and No. 254 is used as a null address for reporting problems when an address cannot be found. Addresses 253 and 252 are reserved for future use.

With regard to addressing, ISO 11783-5 provides for different types of devices. Some are self-configurable and have the ability to claim an address at turn-on, take an address from another node, and claim a new address if theirs is taken. Other devices have fixed, or manually settable, addresses that cannot be changed and generally cannot be claimed by others. All NMEA 2000® compliant devices must be self-configurable and capable of claiming addresses according to the ISO 11783-5 protocol.

Part of the address claim procedure, the part that allows one device to take the address of another, involves the use of the device NAME. NAME is the contents of the data field of the Address Claim message and must be unique for every device on the network. It consists of sub-fields containing codes for device function, instance numbers for multiple devices of the same type, manufacturer code, and a unique number assigned by the manufacturer. The latter, like a serial number, must be unique for every device of the same type produced by a manufacturer. During the address claim process, claims for the same address are won by the device whose name has priority.

In addition to NAME, NMEA 2000® provides messages containing additional information about the device. Parameters such as model number, product version, software version, NMEA 2000® version supported, and installation comments are available in separate messages. The more powerful NMEA 2000® request message defined in the data link layer may be used to search fields of these messages and the NAME message for the purpose of building a map of the network to identify the number and types of devices connected.

THE NETWORK LAYER

This layer, to be implemented in future versions of NMEA 2000®, will define how data is routed through a network from source to destination when more than one network segment is included in a system.

Most installations will involve devices that are connected directly together on the same network segment, for these applications this layer will not be needed. For applications when it is desirable to have separate segments or for larger configurations that exceed the maximum length of cable for the network, exceed the maximum number of network connections, or exceed the maximum number functional addresses, the network can be split into more than one network segment.

THE APPLICATION LAYER

The Application layer defines the approved messages, both network management and data messages, that are transmitted on the NMEA 2000® network. In addition manufacturer's proprietary messages may be transmitted as provided for by the data link layer protocol.

Messages transmitted on the network are organized into parameter groups that are identified by a parameter group number (PGN) that appears in the CAN identifier field as either an 8-bit or 16-bit value depending on whether the parameter group is designed as an addressed or a broadcast message. Depending on the amount of data, the parameter group may require one or more CAN frames to transmit the data. The data content for all parameter groups is structured in an organized way using a database containing a number of tables. Data fields are constructed in the following way:

- a) Each data field has a description defined by a data dictionary entry. Data dictionary items are re-used in as many parameter groups as possible. An example of a data dictionary item is:
 - Wind Direction, True – Direction from which the wind blows. Degrees relative to true north.
- b) Each data dictionary item is of a defined format, usually representing the physical parameter being defined. Physical parameters are finite so there are fewer data format entries than data dictionary entries. The data formats are based upon the International System of Units (SI). In the case of "Wind Direction, True" the data format is:
 - Angle: Units = radian, range = 0 to 2π , resolution = 1×10^{-4}
- c) Every defined data format is represented by a standard data type such as Character, Integer, Unsigned Integer, Float, or Bit Field. The data type for "Angle" is:

- uint16: 16-bit unsigned integer, range 0 to 65,532. 65,533 = Reserved. 65,534 = Out of range. 65,535 = Data not available.

The information necessary to describe a parameter group is illustrated in the Parameter Group Definition table for Distance Log Data. The data represents the cumulative voyage distance traveled. This NMEA 2000® message is a global broadcast message (Destination = Global) with a default priority level of "6", the application that is running may change the priority level over the range 0 to 7. This message requires fourteen data bytes and is not a single-frame message.

The Distance Log Data message is a fast-packet message requiring 3 CAN frames. The message consists of 4 data fields spread over the 3 frames. The boundaries of the data fields with respect to the CAN frames have no significance and it is a task of the receiving node to reassemble the fields from the received frames. The time and date may be initialized or modified by setting data fields 1 and 2 with the Command Group Function message. If the device does not know the time and date when this PGN is generated, then the time and date fields should indicate this with the appropriate values. For a uint16 data type, as in the Date field, the value that indicates "Data not available" is 65,535. For a unit32 data type, as in the Time field, the value that indicates "Data not available" is 4,294,967,295. Definitions for the information in all 4 data fields are provided in the Data Dictionary.

NMEA 2000® MESSAGES

A list of parameter groups (messages) as of version 1.000 is provided here for reference. Since new messages are continually being added, this list should be used only as an example of the type of messages that are provided by NMEA 2000®

NETWORK MANAGEMENT PARAMETER GROUPS

Acknowledgement, basic
Acknowledgment Group Function
Address Claim
Address, Commanded
Configuration Information
Command Group Function
Product Information
Proprietary, Addressed
Proprietary, Global
Received PGN List Group Function

Distance Log

PGN: 128275

This PGN provides the cumulative voyage distance traveled since the last reset. The distance is tagged with the time and date of the distance measurement. The distances through water are accumulated and the values stored during power down and resume counting after power up.

- Total Cumulative Distance is normally set to zero when the log is installed and never reset after that.
- Distance Since Last Reset may manually be set to zero at any time during the voyage and starts to count up from there.
- The "Distance Since Last Reset" is reset by setting the "Distance Since Last Reset" value to 0 with the "Command Group Function" PGN 126208..

Single Frame: No *Priority Default:* 6 *Default Update* 1,000milliseconds *Frequency:* 1.cycles per second

Destination: Global *Query Support:* Opt'l *ACK Rqmnts:*

Field	Field Name	Byte Field	Bit Field	Request	No	Original Reference ID # 39
1	Measurement Date DD039 Generic date	<i>Byte Field 2</i> Days since January 1, 1970,	<i>Bit Field</i> Date is relative to UTC Time.	<i>Request</i>	<i>No</i>	<i>Size: Parameter</i>
	DF41 Date, day count	uint16 <i>Range:</i> 0 to 65,532 days	<i>Resolution</i> 1 day			0 = January 1, 1970, max = ~179 years
2	Measurement Time DD158 Generic time of day	<i>Byte Field 4</i> 24 hour clock, 0 = midnight, time is in UTC	<i>Bit Field</i>	<i>Request</i>	<i>No</i>	<i>Size: Parameter</i>
	DF06 Time of day	uint32 <i>Range:</i> 0 to 86,401 s	<i>Resolution</i> 1x10E-4 s ~24 hours, 0 = midnight, range allows for up to two leap seconds per day			
3	Total Cumulative Distance DD120 Distance, voyage	<i>Byte Field 4</i>	<i>Bit Field</i>	<i>Request</i>	<i>No</i>	<i>Size: Parameter</i>
	DF11 Distance, long	uint32 <i>Range:</i> .0 to ~4.295x10E+7	<i>Resolution</i> 1 m			
4	Distance Since Last Reset DD120 Distance, voyage	<i>Byte Field 4</i>	<i>Bit Field</i>	<i>Request</i>	<i>No</i>	<i>Size: Parameter</i>
	DF11 Distance, long	uint32 <i>Range:</i> 0 to ~4.295x10E+7	<i>Resolution</i> 1 m			

Request, basic
Request Group Function
Transport Protocol, Connection Management
Transport Protocol, Data Transfer
Transmitted PGN List Group Function

APPLICATION PARAMETER GROUPS

Attitude
Battery Status
Bearing and Distance between two Marks
Binary Switch Bank Status
COG & SOG, Rapid Update
Cross Track Error
Current Station Data
Datum
DGNSS Corrections

Direction Data
Distance Log
DSC Call Information
Engine Parameters, Dynamic
Engine Parameters, Rapid Update
Engine Parameters, Static
Environmental Parameters
Fluid Level
GLONASS Almanac Data
GNSS Control Status
GNSS Differential Correction Receiver Interface
GNSS Differential Correction Receiver Signal
GNSS DOPs
GNSS Position Data
GNSS Pseudorange Error Statistics
GNSS Pseudorange Noise Statistics

GNSS RAIM Output
GNSS RAIM Settings
GNSS Sats in View
GPS Almanac Data
Heading/Track Control
Loran-C Range Data
Loran-C Signal Data
Loran-C TD Data
Meteorological Station Data
Moored Buoy Station Data
Navigation Data
Position, Rapid Update
Radio Frequency/Mode/Power
Rudder
Salinity Station Data
Set & Drift, Rapid Update
Small Craft Status
Speed
Switch Bank Control
System Time
Tide Station Data
Time & Date
Time to/from Mark
Tracked Target Data
Transmission Parameters, Dynamic
Trip Parameters, Small Craft
User Datum Settings
Vessel Heading
Vessel Speed Components
Water Depth
Wind Data

CERTIFICATION

The National Marine Electronics Association provides a self-certification tool to aid manufacturers in testing their product(s) during development and prior to final release. The NMEA requires that any device providing a NMEA 2000® interface must pass the self-certification test before that product may claim that it offers NMEA 2000®. This is to ensure that all NMEA 2000® based devices implement the network protocols properly. This testing also ensures that the automatic self-configuring capabilities defined by the NMEA 2000® standard are properly implemented and do not for any reason, cause or generate problems for other equipment on the network. The testing is designed to expose any flaws or weaknesses in the NMEA 2000® protocol implementation and ensure that all devices from all manufacturers behave in a known and predictable manner on the network. This testing does not validate the data or measurements provided by a device, only how it interacts on the network.

The certification tool consists of both hardware (a dual CAN pc-card, cables, and network terminators) and software that runs under several variants of the Microsoft

Windows operating systems. The software is designed to walk the user through all required tests. Some tests require physical measurements (such as voltage levels or ground isolation) and are referred to as manual tests. The software prompts the user for the information needed for each manual test and stores the information in a database. At any time, the user can instruct the software to conduct the many network protocol tests; these are referred to as automated tests. The results of these tests are added to the test database on the users PC. The user can observe the results of each test on-screen, and is provided with an ASCII file of the complete test results. In order to receive certification, the encrypted test data base file must be sent to NMEA for validation. Only after a device has passed all the tests successfully, and NMEA has validated the results, can a device be NMEA 2000® certified.

STANDARD DOCUMENTATION

The NMEA 2000® standard spans several hundred pages. The bulk of these are the definitions of the parameter groups (messages). The remaining portion of the information consists of the minimum requirements, certification requirements and application notes. Due to the size, complexity, and OSI model layout of the standard, the NMEA 2000® standard spans a main document and 7 Appendices. This organization allows updates to be made to specific sections when necessary without having to update sections that do not change. The NMEA 2000® Standard for Serial-Data Networking of Marine Electronic Devices is provided in the following documents:

NMEA 2000® – Main Document

Appendix A – Application Layer (Parameter Group Definitions)

Appendix B – Data Base Reports (Parameter Groups)

Appendix C – Certification Criteria and Test Methods

Appendix D – Application Notes

Appendix E – ISO 11783-5 Network Management

Appendix F – ISO 11783-3 Data Link Layer

Appendix G – ISO 11898 Controller Area Network (CAN)

In addition to the printed documents, NMEA 2000® is provided on CD-ROM with the exception of the ISO documents. The documents are in Adobe PDF format, and the parameter group definitions are provided in a Microsoft Access database with search and report generation capabilities. Sample source code for the Auto-Address Claim method required by the standard is provided on CD-ROM as a guide to those implementing the standard.

REFERENCES

1. National Marine Electronics Association, NMEA 2000® Standard for Serial-Data Networking of

- Marine Electronic Devices, Version 1.000, September 12, 2001.
2. National Marine Electronics Association, NMEA 0183 Standard for Interfacing Marine Electronic Devices, Version 3.01, January 1, 2002.
 3. International Organization for Standardization (ISO) 11783-5, Part 5 Network Management - Tractors and Machinery for Agricultural and Forestry – Serial Control and Communications Data Network, First edition, 2001-05-01.
 4. International Organization for Standardization (ISO) 11783-3, Part 3 Data Link Layer - Tractors and Machinery for Agricultural and Forestry – Serial Control and Communications Data Network, First edition, 1998-07-01
 5. International Organization for Standardization (ISO) 11898, Road Vehicles - Interchange of Digital Information - Controller Area Network (CAN) for High-speed Communications, First Edition, 1993-11-15.
 6. Society of Automotive Engineers (SAE) J1939 - Recommended Practice for a Serial Control and Communications Vehicle Network, 2000-04.
 7. Society of Automotive Engineers (SAE) J1939-21- Data Link Layer, 1998-07.
 8. Society of Automotive Engineers (SAE) J1939-81- Network Management, 1997-07.